

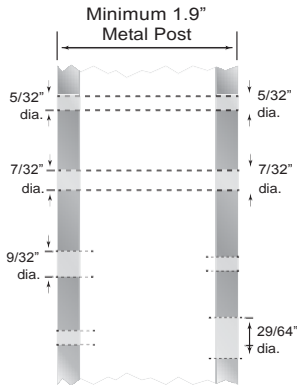

Vista Cable Rail Kit 102 Series Installation Instructions for Wood Posts on Level Runs

Hole size for 1/8" or 3/16" dia. cable installation

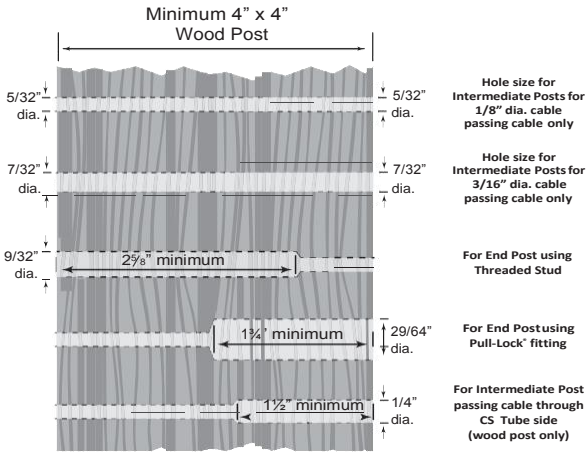

Drill Posts



A. Install Tensioning Terminal

1. Install the Threaded Stud end first. Feed the cable and stud through the end post. Slide the stainless steel washer (smaller for metal post, larger for wood post) onto the Threaded Stud and start the brass locknut onto the threads as far as possible by hand.

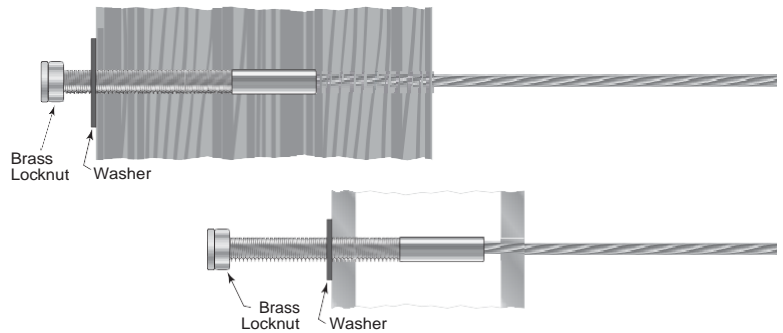

B. Feed Cable through Intermediate Posts

1. Feed the bare end of the cable through all your intermediate posts/cable braces and through the end post where you will be installing the Pull-Lock fitting.

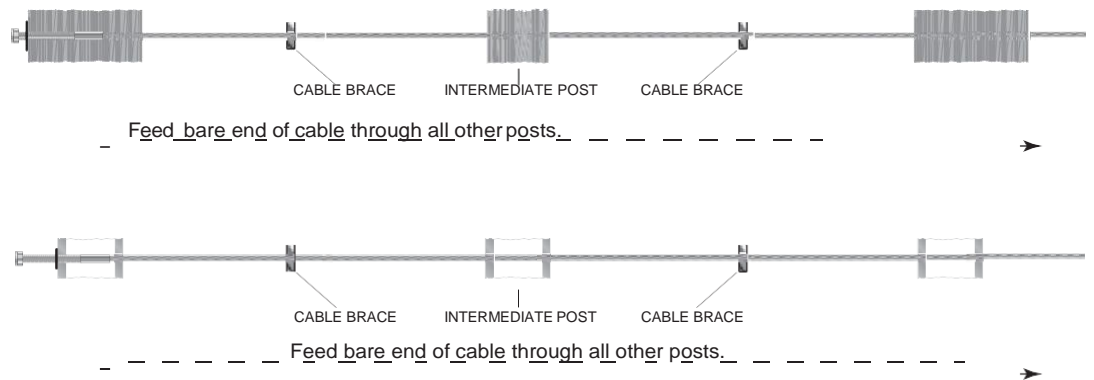

C. Install Swageless Terminal

1. Slip the appropriate washer over the body of the Pull-Lock® fitting (Delrin® for metal post, stainless steel for wood post).

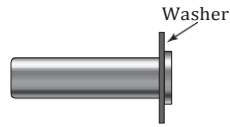

2. Rotate the Pull-Lock® fitting clockwise as you push it onto the cable. If the cable begins to “unravel,” you are rotating the fitting in the wrong direction.

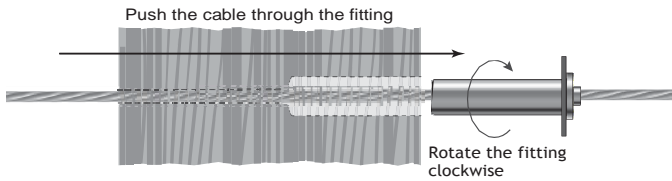

Note: If you have trouble inserting the cable into the fitting, it may be because the locking wedges have become stuck. This is not a defect! Here's what you can do to “free the wedges” – For Pull-Lock® or Push-Lock® fittings for 1/8” cable, using either a PL-KEY or 1/4” diameter bolt, insert the PL-KEY or bolt into the hole and press until the wedges move freely. Perform the same operation for a 3/16” Pull-Lock® or Push-Lock®, except use a 16d nail or another tool with 1/8” or smaller diameter. Anything larger than what is recommended can actually get stuck inside the fitting – NOT what you want!

3. Push the Pull-Lock® fitting along the cable and firmly into the hole in your post. While holding the Pull-Lock® fitting against the end post, pull the bare end of the cable to remove as much slack in the cable as possible.

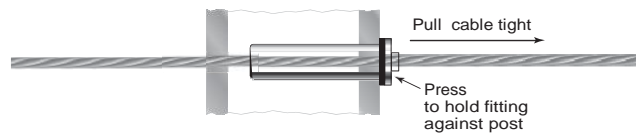

4. Cut the cable flush with the hole in the back of the fitting using a cut-off wheel.



5. Press the optional cap onto the lip of the Pull-Lock® fitting.

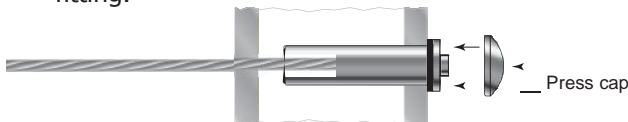

— onto lip

D. Tension Cables

1. Return to the Threaded Stud end post. Insert an 1/8” hex wrench into broached opening on the tip of the stud. Tighten the locknut with a 7/16” wrench while holding the hex wrench to prevent the stud from turning.

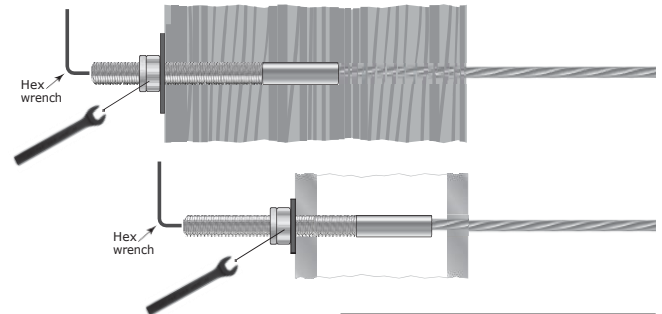

2. Tension all cables to desired amount in sequence, beginning with the center cables, moving up and down toward the top and bottom. As you tension each cable, give it a sharp pull downward mid-span to help set the wedges, then re-tension as necessary in the same sequence.

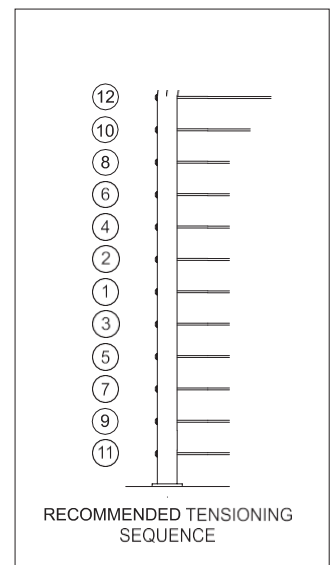

3. When all of the cables are tight, cut off any exposed thread as near to the locknut as possible by using a cut-off wheel or hack saw.

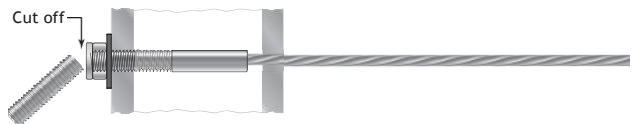
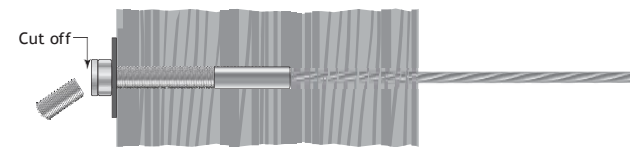

4. If you have purchased the optional nut cap, press the cap over the locknut.

